

mechanical APPLICATION

Many SWAROVSKI ELEMENTS, such as Rivets, Jeans Buttons, Snap Fasteners, Decorative Buttons and Magnet Fasteners, can be applied manually or mechanically, using either semi- or fully automated machines. This simple application technique is used primarily in the textile and accessories fields.





PRODUCT OVERVIEW

<<<

The following products are suitable for mechanical application:

MECHANICAL APPLICATION	
Snap Fasteners	✓
Decorative Buttons	✓
Jeans Buttons	✓
Magnet Fasteners	✓
Rivets	✓
Crystal Pearl Rivets	✓
Rose Pins	✓

MACHINES, TOOLS, AND AIDS

<<<

The following machines, tools and aids are necessary for the mechanical application of SWAROVSKI ELEMENTS:



The **fly press** represents an easy way to mechanically apply the products.
Art. 9040/017



The **pneumatic press** enables quick application of crystal elements.



Some SWAROVSKI ELEMENTS can be applied using fully **automatic attaching machines** (e.g. Rose Pins). In this process, the feed on the machine must be adjusted to the element being processed.



Vacuum pump SP 302 SL-V with silicone hose allows Rivets and Rose Pins to be easily held in place for the fly press.
Art. 9040/022



It is recommended that **protective eyewear** is worn during mechanical application, to prevent injury.

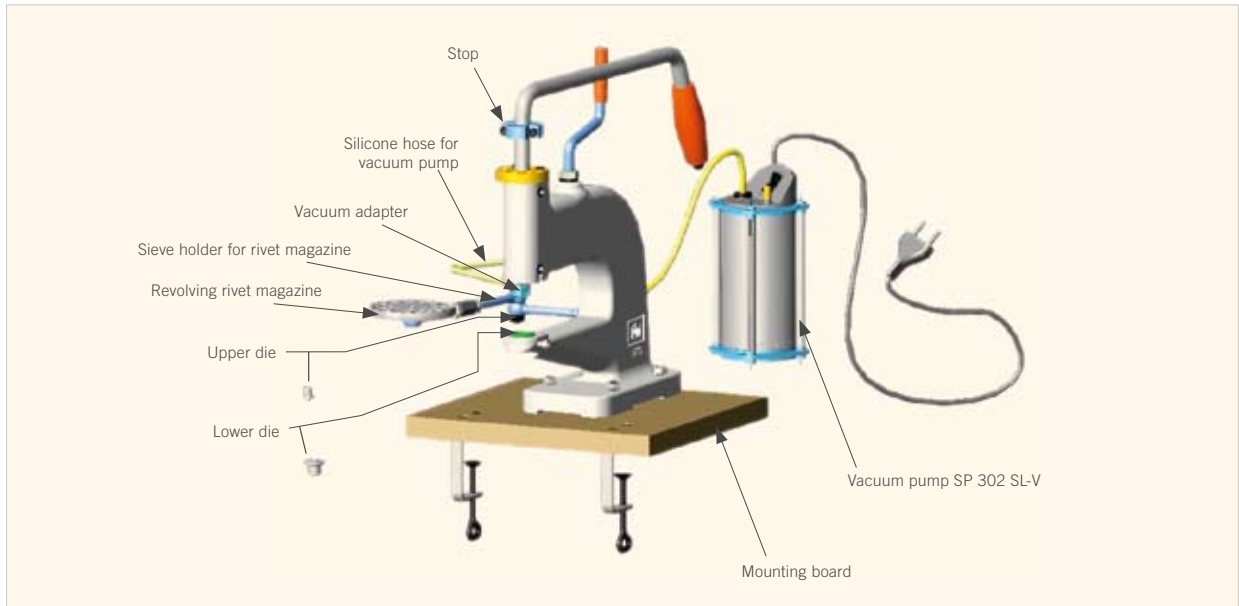

Swarovski offers a variety of different tools for the fly press, depending on the product employed.



Fly press including possible dies and aids for application (in this case, of Rivets)

Rose Pins

A vacuum pump allows Rose Pins to be easily picked up and applied. The vacuum connection is integrated directly into the upper die. An additional vacuum adapter is not necessary.

	53301 SS 10	53302 SS 16	53303 SS 20	53304 SS 34
UPPER DIE 	Art. 9040/090 (M6)	Art. 9040/091 (M6)	Art. 9040/092 (M6)	Art. 9040/093 (M6)
SPARE PART FOR UPPER DIE* 	Art. 9040/094	Art. 9040/095	Art. 9040/096	Art. 9040/097
LOWER DIE 	Art. 9070/013	Art. 9070/014		Art. 9070/016

* The spare part is integrated into the upper die as standard. This should be changed when it becomes worn.











The **centering aid** for Rose Pins 53301 (SS 10) Art. 9070/017 allows the product to be easily positioned in the upper die.

Rivets

Rivets can be applied to various materials **with or without** Back Parts. The **correct die combination** must be chosen accordingly. Please ensure that the recommended fabric strengths, listed in the “Application” subsection (p. 136), are followed.

A vacuum pump and adapter allow Rivets and Crystal Pearl Rivets to be easily picked up and applied. Upper dies are thus available with different thread strengths. When using the Swarovski vacuum adapter, dies with an M8 thread are required. Alternatively, dies with M6 threads are available for presses from other manufacturers, or when not using a vacuum adapter.



POSSIBLE DIE COMBINATIONS		BACK PART	WITH BACK PART		WITHOUT BACK PART	
			53007	53009	RIVET CASING 088	RIVET CASING 081; 082; 086
						
		LOWER DIE	Art. 9070/010 	Art. 9070/012 	Art. 9070/011 	Art. 9040/015 
RIVETS	UPPER DIE 	Spare part for upper die* 				
53008 PP 24	Art. 9040/083 (M8)	Art. 9040/084		✓	✓	
	Art. 9040/085 (M6)					
53002 SS 18 (SHORT SHANK)	Art. 9040/005 (M8)	Art. 9040/008				✓
	Art. 9040/014 (M6)					
53000 SS 18	Art. 9040/005 (M8)	Art. 9040/008	✓	✓	✓	✓
	Art. 9040/014 (M6)					
53001 SS 29	Art. 9070/005 (M8)	Art. 9070/008	✓	✓	✓	✓
	Art. 9070/009 (M6)					
53005 SS 34	Art. 9040/064 (M8)	Art. 9040/062	✓	✓	✓	✓
	Art. 9040/063 (M6)					
53006 SS 39	Art. 9040/067 (M8)	Art. 9040/065	✓	✓	✓	✓
	Art. 9040/066 (M6)					
53400 6 MM	Art. 9040/068 (M8)	Art. 9040/074	✓	✓		✓
	Art. 9040/071 (M6)					
53401 8 MM	Art. 9040/069 (M8)	Art. 9040/075	✓	✓		✓
	Art. 9040/072 (M6)					
53402 10 MM	Art. 9040/070 (M8)	Art. 9040/076	✓	✓		✓
	Art. 9040/073 (M6)					

* The spare part is integrated into the upper die as standard. This should be changed when it becomes worn.













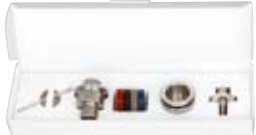

Vacuum adapter with M6 outer thread for fixing to the fly press and M8 inner thread to hold the upper die.
Art. 9040/023



Custom aids (revolving magazine, setting frame, sieve holder for rivet magazine) facilitate the mechanical application of Rivets.







Jeans Buttons

	1790/100 1790/114	1790/104	1790/140	1791/120	1792/100
TOOL SET	—	Art. 9060/020 			
UPPER DIE	Art. 9060/001 	Art. 9060/009 			
SPARE PART FOR UPPER DIE	—	Art. 9060/011 	Art. 9060/010 	Art. 9060/012 	Art. 9060/013 
LOWER DIE	Art. 9060/016 				
THREAD ADAPTER	— ²	Art. 9060/014 ¹ 			
CHANGING PIN	—	Art. 9060/015 			

¹ When using die Art. 9060/009, please employ the specially developed thread adapter Art. 9060/014.

² The appropriate thread adapter is supplied with the fly press.

Decorative Buttons, Snap Fasteners, and Magnet Fasteners

	1780/100 1780/114 1781/100 1781/114 	1780/100 1780/114 	86200 200 86201 200 86202 200 86203 200 
UPPER DIE	Art. 9060/005 	Art. 9060/006 	Art. 9040/052 
LOWER DIE	Art. 9060/004 	Art. 9060/007 	Art. 9040/053 

SUPPLIERS



This list provides an overview of select suppliers worldwide.

MACHINES / TOOLS / AIDS	SUPPLIER	CONTACT
Automatic attaching machines	Jiuzhou Machinery Co., Ltd.	www.dg-jz.com
	Prym-Fashion	www.prym-fashion.com
	Seung Min Industrial Co., Ltd.	www.seungminsm.co.kr
	S.P.S. Tecnologia Meccanica Srl	www.spstecnologiameccanicasrl.it
Pneumatic attaching machines	Prym-Fashion	www.prym-fashion.com
Fly press	Swarovski fly press without mounting board, Art. 9040/017	www.swarovski-elements.com/business
	Fly press with mounting board*, Art. 9040/019	
	Jiuzhou Machinery Co., Ltd.	www.dg-jz.com
	Seung Min Industrial Co., Ltd.	www.seungminsm.co.kr
	Standard Rivet Company	www.standardrivet.com
Upper die (M6) for Rose Pins (fly press)	Swarovski For Rose Pin 53301, Art. 9040/090	www.swarovski-elements.com/business
	For Rose Pin 53302, Art. 9040/091	
	For Rose Pin 53303, Art. 9040/092	
	For Rose Pin 53304, Art. 9040/093	

MACHINES / TOOLS / AIDS	SUPPLIER	CONTACT
Lower die for Rose Pins (fly press)	Swarovski For Rose Pin 53301, Art. 9070/013 For Rose Pin 53302 and 53303, Art. 9070/014 For Rose Pin 53304, Art. 9070/016	www.swarovski-elements.com/business
Spare part for upper die for Rose Pins (fly press)	Swarovski For Art. 9040/090 (Rose Pins 53301), Art. 9040/094 For Art. 9040/091 (Rose Pins 53302), Art. 9040/095 For Art. 9040/092 (Rose Pins 53303), Art. 9040/096 For Art. 9040/093 (Rose Pins 53304), Art. 9040/097	www.swarovski-elements.com/business
Centering aid for Rose Pin 53301	Swarovski, Art. 9070/017	www.swarovski-elements.com/business
Basic fly press set for Rivets (components identified with *)	Swarovski, Art. 9070/018	www.swarovski-elements.com/business
Vacuum pump SP 302 SL-V* with silicone hose	Swarovski, Art. 9040/022	www.swarovski-elements.com/business
Vacuum adapter for Rivets*	Swarovski, Art. 9040/023	www.swarovski-elements.com/business
Sieve holder for Rivets*	Swarovski, Art. 9040/021	www.swarovski-elements.com/business
Upper die (M8) for Rivets (fly press)	Swarovski For Rivet 53000 and 53002, Art. 9040/005 For Rivet 53001, Art. 9070/005 For Rivet 53005, Art. 9040/064 For Rivet 53006, Art. 9040/067 For Rivet 53008, Art. 9040/083	www.swarovski-elements.com/business
Upper die (M6) for Rivets (fly press)	Swarovski For Rivet 53000 and 53002, Art. 9040/014 For Rivet 53001, Art. 9070/009 For Rivet 53005, Art. 9040/063 For Rivet 53006, Art. 9040/066 For Rivet 53008, Art. 9040/085	www.swarovski-elements.com/business
Upper die (M8) for Crystal Pearl Rivets (fly press)	Swarovski For Crystal Pearl Rivet 53400, Art. 9040/068 For Crystal Pearl Rivet 53401, Art. 9040/069 For Crystal Pearl Rivet 53402, Art. 9040/070	www.swarovski-elements.com/business
Upper die (M6) for Crystal Pearl Rivets (fly press)	Swarovski For Crystal Pearl Rivet 53400, Art. 9040/071 For Crystal Pearl Rivet 53401, Art. 9040/072 For Crystal Pearl Rivet 53402, Art. 9040/073	www.swarovski-elements.com/business

MACHINES / TOOLS / AIDS	SUPPLIER	CONTACT
Lower die for Rivets and Crystal Pearl Rivets (fly press)	Swarovski For Rivet application with a Back Part 53007, Art. 9070/010 For Rivet application with a Back Part 53009, Art. 9070/012 For Rivet application without a Back Part, (Rivet casing 088), Art. 9070/011 For Rivet application without a Back Part, (Rivet casing 081, 082 and 086), Art. 9040/015	www.swarovski-elements.com/business
Spare part for upper die for Rivets (fly press)	Swarovski For Art. 9040/005 and 9040/014 (Rivets 53000 and 53002), Art. 9040/008 For Art. 9070/005 and 9070/009 (Rivets 53001), Art. 9070/008 For Art. 9040/064 and 9040/063 (Rivets 53005), Art. 9040/062 For Art. 9040/067 and 9040/066 (Rivets 53006), Art. 9040/065 For Art. 9040/083 and 9040/085 (Rivets 53008), Art. 9040/084	www.swarovski-elements.com/business
Spare part for upper die for Crystal Pearl Rivets (fly press)	Swarovski For Art. 9040/068 and 9040/071 (Crystal Pearl Rivet 53400), Art. 9040/074 For Art. 9040/069 and 9040/072 (Crystal Pearl Rivet 53401), Art. 9040/075 For Art. 9040/070 and 9040/073 (Crystal Pearl Rivet 53402), Art. 9040/076	www.swarovski-elements.com/business
Setting frame for revolving magazine	Swarovski, Art. 9040/009	www.swarovski-elements.com/business
Revolving magazine for Rivets*	Swarovski For Rivets 53000, 53001, 53005 and 53006, Art. 9040/002 For Rivet 53008, Art. 9040/082	www.swarovski-elements.com/business
Sieve plate for Crystal Pearl Rivets	Swarovski, Art. 9040/080	www.swarovski-elements.com/business
Rotary plate for Crystal Pearl Rivets	Swarovski, Art. 9040/081	www.swarovski-elements.com/business
Tool set for Jeans Buttons 1790/104, 1790/140, 1791/120 and 1792/100	Swarovski, Art. 9060/020	www.swarovski-elements.com/business
Upper die for Jeans Buttons 1790/100 and 1790/114	Swarovski, Art. 9060/001	www.swarovski-elements.com/business
Upper die for Jeans Buttons 1790/104, 1790/140, 1791/120 and 1792/100	Swarovski, Art. 9060/009	www.swarovski-elements.com/business
Lower die for Jeans Buttons 1790/100, 1790/114, 1790/104, 1790/140, 1791/120 and 1792/100	Swarovski, Art. 9060/016	www.swarovski-elements.com/business

MACHINES / TOOLS / AIDS	SUPPLIER	CONTACT
Spare part for upper die	Swarovski For Jeans Button 1790/104, Art. 9060/011 For Jeans Button 1790/140, Art. 9060/010 For Jeans Button 1791/120, Art. 9060/012 For Jeans Button 1792/100, Art. 9060/013	www.swarovski-elements.com/business
Thread adapter for Jeans Buttons 1790/104, 1790/140, 1791/120 and 1792/100	Swarovski, Art. 9060/014	www.swarovski-elements.com/business
Changing pin for upper die spare part	Swarovski, Art. 9060/015	www.swarovski-elements.com/business
Upper die for Decorative Buttons 1781/100 and 1781/114 and Snap Fasteners 1780/100 and 1780/114 (1st stage)	Swarovski, Art. 9060/005	www.swarovski-elements.com/business
Upper die for Snap Fasteners 1780/100 and 1780/114 (2nd stage)	Swarovski, Art. 9060/006	www.swarovski-elements.com/business
Lower die for Decorative Buttons 1781/100 and 1781/114 and Snap Fasteners 1780/100 and 1780/114 (1st stage)	Swarovski, Art. 9060/004	www.swarovski-elements.com/business
Lower die for Snap Fasteners 1780/100 and 1780/114 (2nd stage)	Swarovski, Art. 9060/007	www.swarovski-elements.com/business
Upper die for Magnet Fasteners (fly press)	Swarovski, Art. 9040/052	www.swarovski-elements.com/business
Lower die for Magnet Fasteners (fly press)	Swarovski, Art. 9040/053	www.swarovski-elements.com/business

Various SWAROVSKI ELEMENTS can be applied using mechanical force, creating a lasting bond with the carrier material.

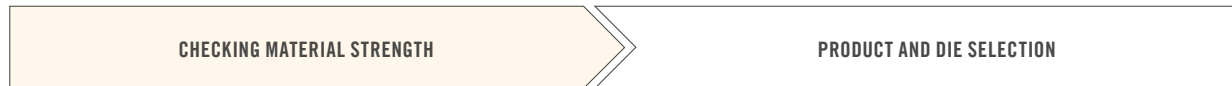

It is very important to carefully check the thickness of the fabric or leather before beginning the application process. With very thick fabrics, a hole can be punched beforehand for the application of Jeans Buttons and Rivets. The fabric should not crinkle or become gathered after application. To check this, carry out tests on fabric or leather scraps before going ahead with the application process. It is also important to make sure that the die sits straight and firmly in the fly press, as this can often cause application problems. It is recommended that you carry out a few test runs to identify the ideal pressure. The offset/pressure can be regulated using an adjustable stop that is fastened to the handle of the fly press. **?!**



Rose Pins

Rose Pins can be easily applied either using the fly press or with a semi-automatic attaching machine. Please note the material thickness when selecting Rose Pins.

ROSE PINS	SIZE	MATERIAL THICKNESS*
53301	SS 10	1-2 mm
53302	SS 16	1-2 mm
53303	SS 20	1-2 mm
53304	SS 34	1-2 mm

* This can vary according to the roughness and production of the carrier material.

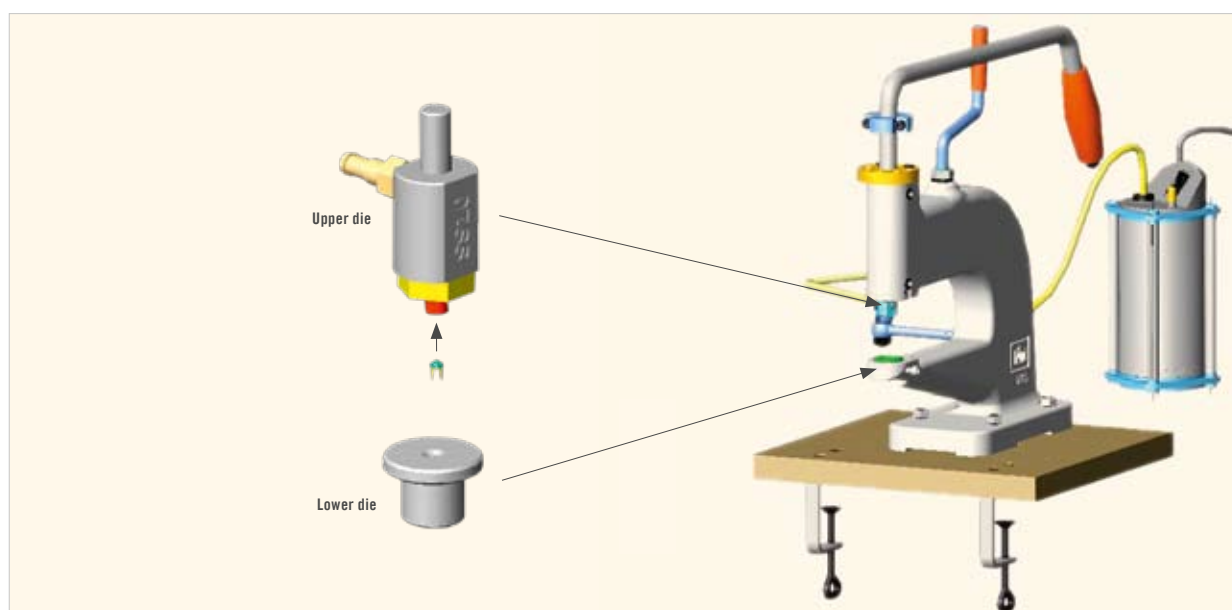

To apply Rose Pins, attach the appropriate die to the fly press.



1 Place the Rose Pin in the upper die.



2 Position the carrier material and apply. Regulate the offset/pressure using the adjustable stop.

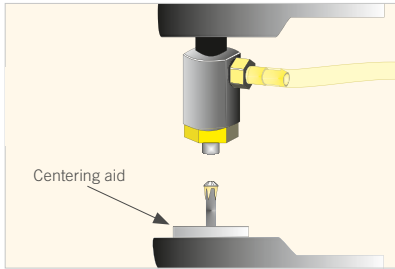

To facilitate the positioning of the Rose Pin 53301 (SS 10) in the upper die, the centering aid can also be used. This must be removed before applying the Rose Pin.

Semi-automatic attaching machine

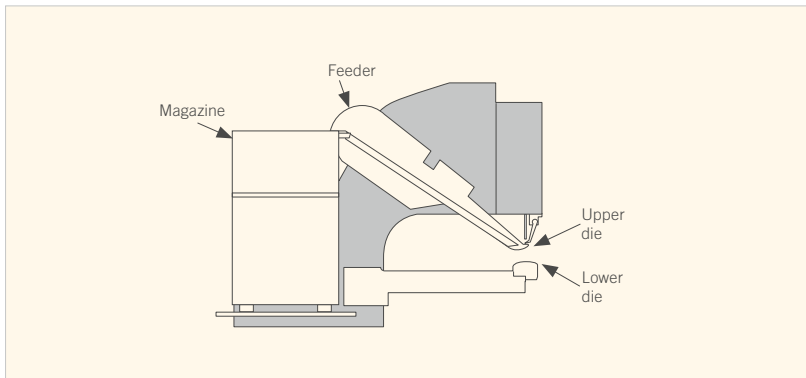

To apply Rose Pins, the semi-automatic attaching machine must be adjusted to the Rose Pin size and carrier material (dies, feed and magazine). Please follow the machine manufacturer's instructions (S.P.S. Tecnologia Meccanica).



1 Set up the machine.



2 Add the Rose Pins.



3 Position the carrier material and apply.

Note: when applying Rose Pins motifs, it is helpful to have a corresponding template or marking on the carrier material so as to ensure the correct positioning.

Rivets

To apply Rivets, attach the appropriate die to the fly press.

Rivets can be processed in various materials with or without Back Parts. Rivet 53002 is designed especially for application without a Back Part. For applications on leather, Stainless Steel Rivets (color code 088) and Back Parts are recommended.

Please note the material thickness when selecting Rivets. The dies should be selected accordingly.

RIVETS	SIZE	MATERIAL THICKNESS*	POSSIBLE BACK PARTS
53008	PP 24	1.5 to 2.0 mm	53009
53000	SS 18	2.0 to 2.5 mm	53007 and 53009
53001	SS 29	2.0 to 2.5 mm	53007 and 53009
53005	SS 34	2.0 to 2.5 mm	53007 and 53009
53006	SS 39	2.2 to 2.7 mm	53007 and 53009
53400	6 mm	2.0 to 2.5 mm	53007 and 53009
53401	8 mm	2.0 to 2.5 mm	53007 and 53009
53402	10 mm	2.2 to 2.7 mm	53007 and 53009

* This can vary according to the roughness and production of the carrier material.

It is often possible to select between both versions of the Back Part. For applications on **thinner fabrics**, it is better to use the **larger** Back Part (Art. 53007). Its size means this Back Part can better hold the split Rivet shaft, avoiding any damage to the crystal.

For **multi-layered or thicker** materials, the **smaller** Back Part (Art. 53009) can be used. To create a lasting bond, this requires less space for the split Rivet shaft. If the carrier material proves too thick, or is made up of several layers, it is recommended to punch a hole before application.

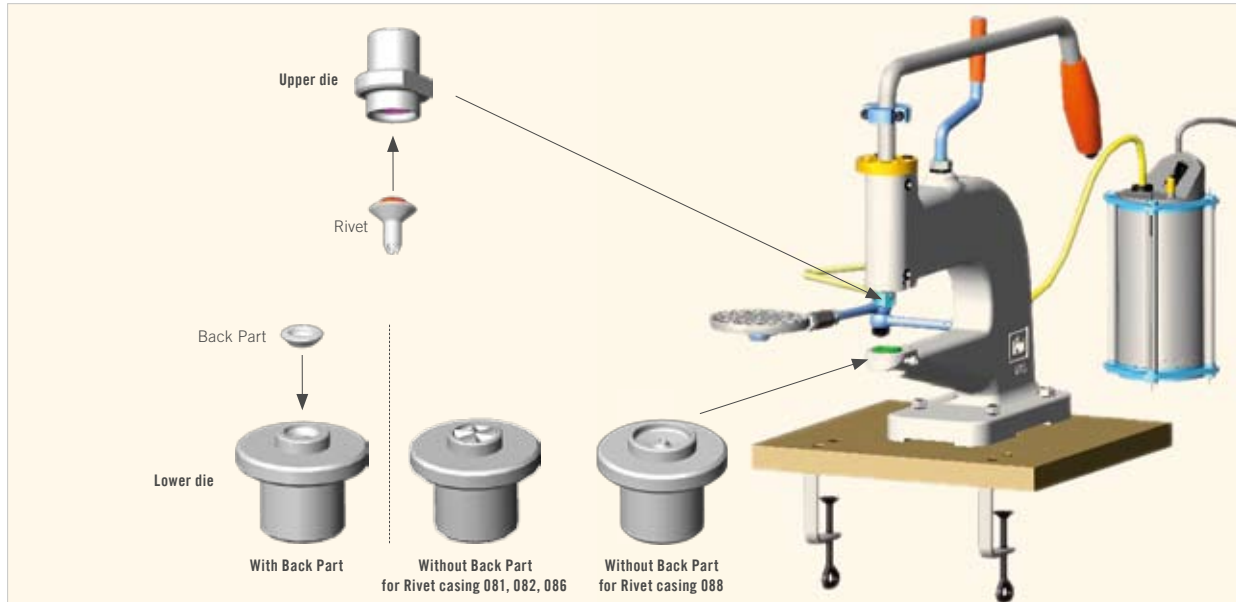

The use of a revolving magazine and setting frame makes it easier and faster to apply the Rivets.



1 Place the revolving magazine in the setting frame.



2 Gently shake the Rivets into the openings provided.



3 Place the magazine with the Rivets into the holder.



4 The Rivets are taken up by means of the vacuum.



5 Position the carrier material and apply. Regulate the offset/pressure using the adjustable stop.

Jeans Buttons

To apply Jeans Buttons, first fix the required dies into place in the fly press. When applying Jeans Buttons 1790/140, 1790/104, 1791/120 and 1792/100, the corresponding plastic insert has to be changed.

Changing the plastic insert



1 To change the insert according to the SWAROVSKI ELEMENTS used, you will need the changing pin and the new plastic insert.



2 Use the changing pin to slowly slide the plastic insert out of the attaching die from above, through the hole.

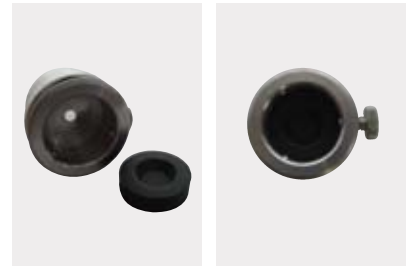

3 Press the new plastic insert into the attaching die right up to the top.

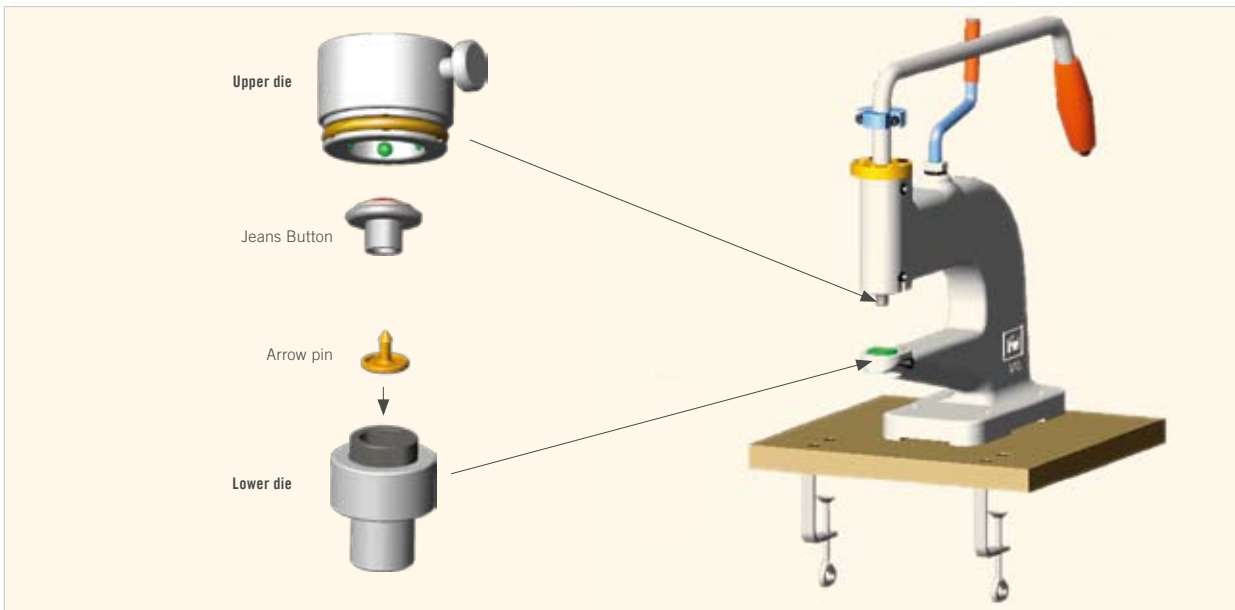

1 Place the top part of the Jeans Button in the upper die.



2 Place the arrow pin in the lower die.



3 Carry out the application in the desired position. Regulate the offset/pressure using the adjustable stop.

Snap Fasteners & Decorative Buttons

To apply Snap Fasteners and Decorative Buttons, first fix the required dies into place in the fly press. A Decorative Button is the upper part of a Snap Fastener, which is applied purely for decorative purposes and thus does not require a closure. When applying Snap Fasteners, a second stage is required in order to fix the closure in place.

Decorative Buttons/upper part of Snap Fasteners

Stage 1:

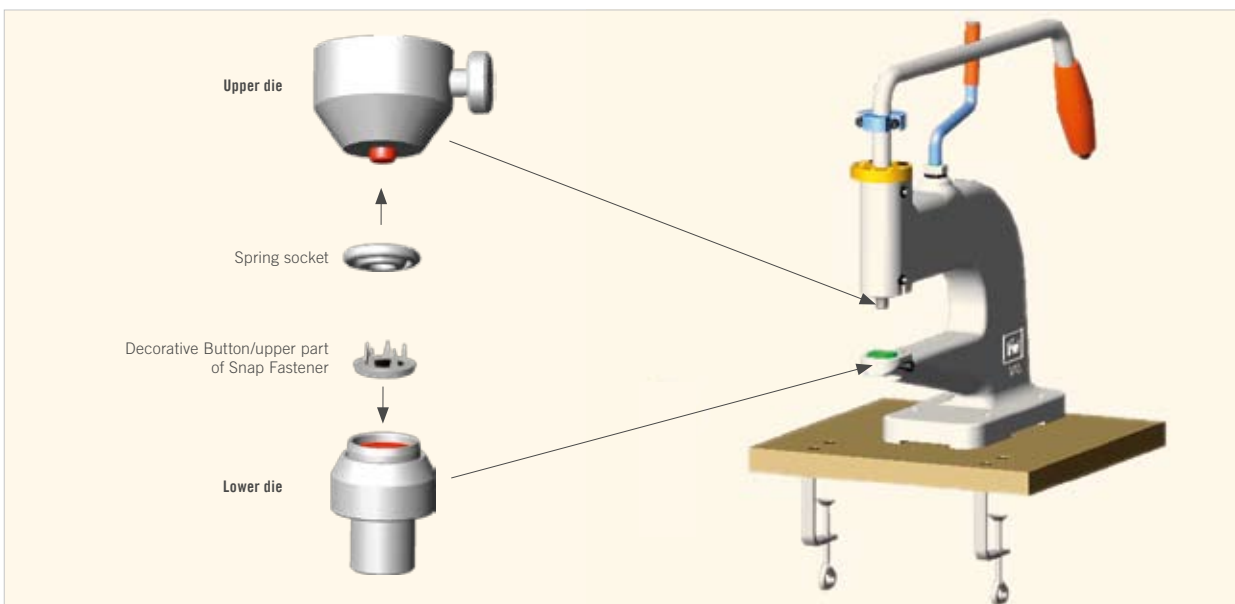



1 Place the Decorative Button/upper part of the Snap Fastener in the lower die, with the claws pointing upwards.



2 Place the spring socket in the upper die.



3 Apply the product to the textile in the previously marked position. Regulate the offset/pressure using the adjustable stop.

Snap Fastener closure

Stage 2:

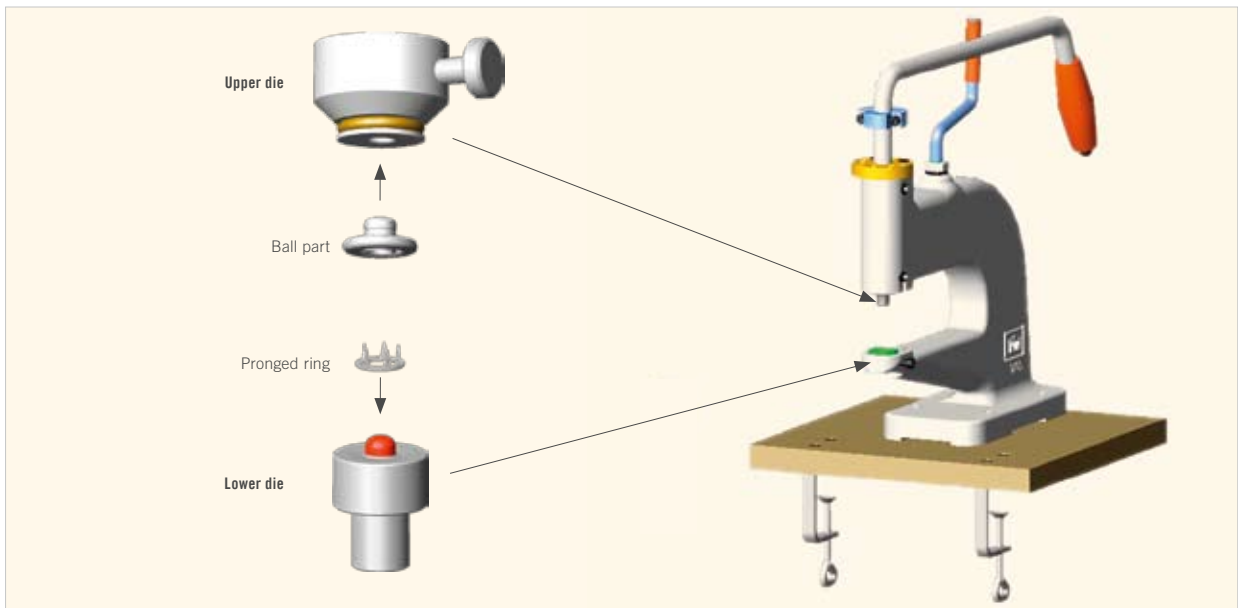

1 Place the pronged ring in the lower die, with the prongs pointing upwards.



2 Place the ball part in the upper die.



3 Apply the product to the textile in the previously marked position, ensuring it is on the right side of the fabric. Regulate the offset/pressure using the adjustable stop

Magnet Fasteners

To apply Magnet Fasteners with the Rivet Fastener (200) configuration, first fix the required dies into place in the fly press.

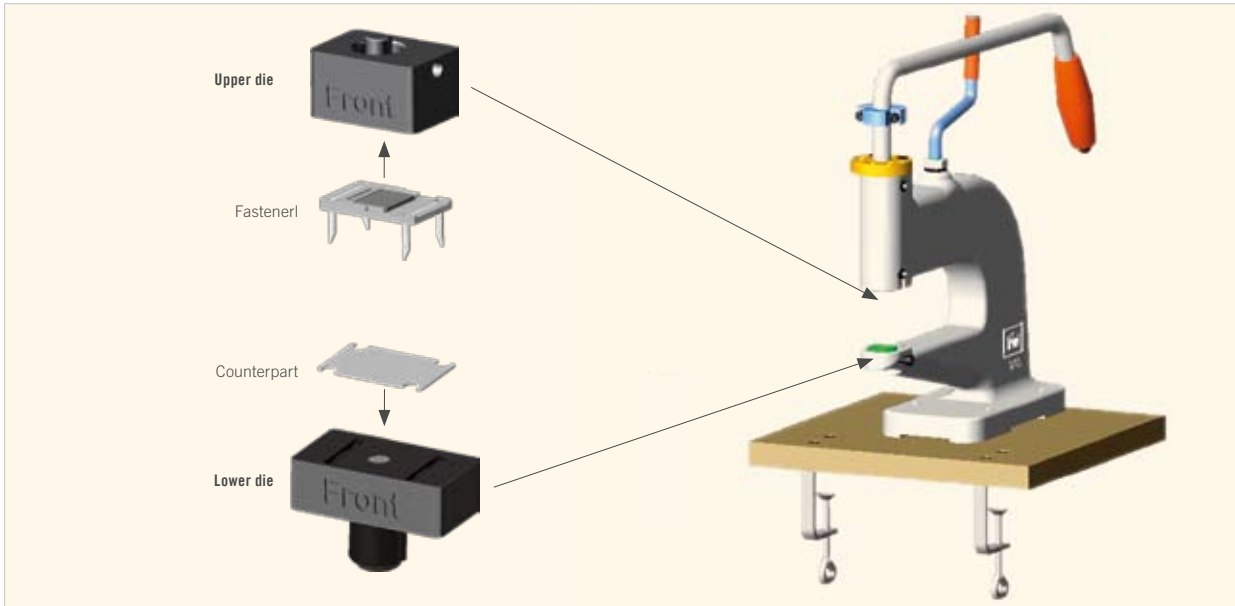

1 Place the dies into the fly press, ensuring that they are positioned in the correct direction ("Front" is facing the front).



2 Put the fastener part with the claws into the upper die and the back part into the lower die, making sure that it is positioned correctly so that the claws fit into the recesses.



3 Insert the carrier material and position it correctly.



4 Press the fly press together and the claws will close. Regulate the offset/pressure using the adjustable stop.



5 Turn the lower die 180° and close the fly press again. Regulate the offset/pressure using the adjustable stop.



6 The second closure presses the claws as flat as possible.

Optimum product/die alignment

In general, when carrying out mechanical applications it is important to ensure the proper alignment of products in the dies, so as to avoid any problems.

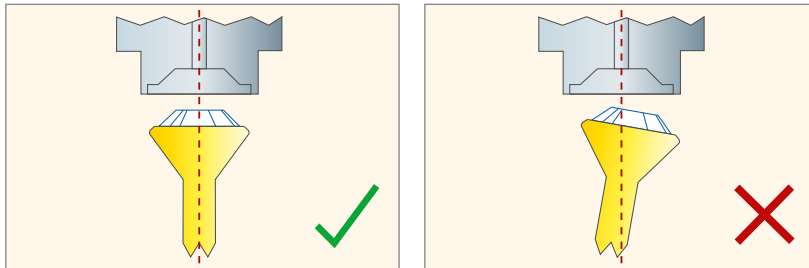

Minimum gaps

Please note that during application, the product is entirely surrounded by the upper die. To prevent neighboring products from being damaged, check the minimum space required by the die when calculating the gap between each item.

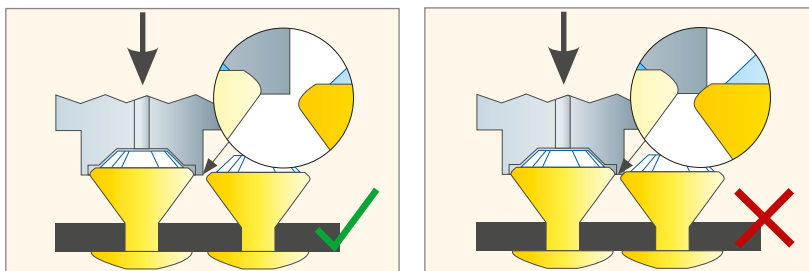

Die maintenance

Please randomly check the dies used before and during production, and change them when they become worn. For machines with vacuum connections, blockages in the upper die can be released using a needle.

QUICK ASSISTANCE

<<<

The following table outlines common problems with mechanical applications and their causes, and offers advice on how to avoid them. Further details and descriptions can be found in the section marked with a **?!**

PROBLEM	CAUSE
The product is not ideally affixed onto the carrier material.	1, 2, 3, 4, 5
The fabric ripples or crinkles.	2, 3, 4, 5
The dies cannot be inserted in the fly press.	3, 6, 7, 8
It is not possible to unscrew the dies.	6, 8, 9
The crystals break.	2, 3, 4, 5, 10
The crystals do not hold in the upper die.	12, 13

CAUSE	RECOMMENDATION
1 The pressure may be too low.	Apply the product again using increased pressure; adjust the stop.
2 The carrier material is too thick or consists of too many layers.	With Rivets, select the smaller Back Part. With Rivets and Jeans Buttons a hole can be pre-punched.
3 The dies/spare parts for the upper die are defective or have been wrongly inserted.	Check the dies and if necessary, replace or repair them.
4 The product has been applied using the wrong dies.	Check to make sure that the right dies are being used for the product.
5 The dies have not been inserted correctly.	Make sure that the products are placed exactly in the right position on the dies. By turning the fly press handle slowly, it is possible to see if the upper and lower parts of the tool meet exactly.
6 The fly press and dies do not fit together.	Make sure that the fly press and the upper die have the same thread size (M6 or M8).
7 The upper die cannot be fitted.	Check the fastening screw on the upper die; it may have been screwed too tightly.
8 The die/spare part may be damaged.	Check the dies; if they are faulty use a new die or spare part.
9 The screw on the upper die has broken off.	Carefully try to loosen the screw using pliers. Oil from time to time; it may be necessary to center-drill the die.
10 The pressure may be too high.	Apply the product again using slightly less pressure; adjust the stop.
11 The die damages the crystal.	Check the dies and if necessary replace the upper die or the spare parts.
12 The vacuum hose is blocked or damaged.	Check and if necessary change the vacuum hose.
13 The vacuum hole in the upper die (Rivet) is blocked.	Clean the vacuum hole and if necessary change the spare part.

